



Wire Management Solution

ACME CABLE CLIP

INSTALLATION INSTRUCTIONS

BURNDY recommends that the sufficient details of the installation be submitted to the AHJ for approval before any work is started.

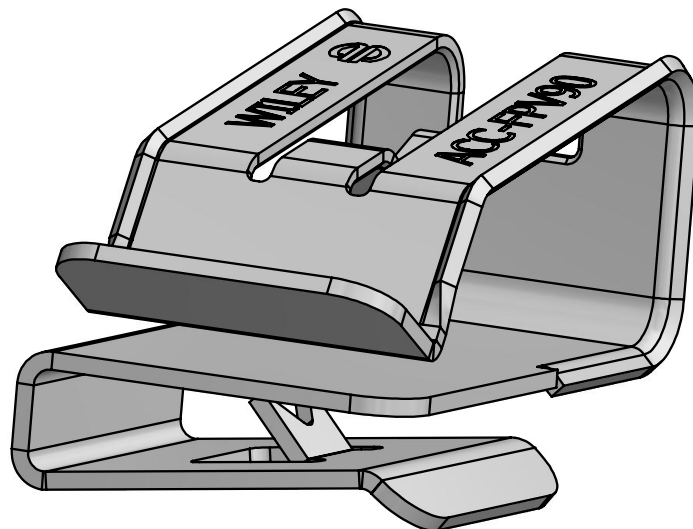

ACC-FPV90

Products are tested to UL 1565 & CSA C22.2 No. 18.5-13,
US/ Canadian standards for safety Positioning Device.

ACC-FPV90 COMPATIBILITY

Wire Management Solutions

Engineered for high-quality wire management solutions, Wiley Cable Clips simplify wire management and lead to safer and more reliable wiring of the solar PV array.

The clips are made of corrosion resistant 304 stainless steel, which makes them a durable, long lasting and reliable solution for all environments.

To install, push clip fully onto module frame. Insert wires by gently pushing into cable compartment. Slight twisting of the wires will ease installation.

The design is easy to install, no tool is required for installation and removal.

Care should be taken to not over bend the clip when adding or removing wires.

Custom designs are available upon request.

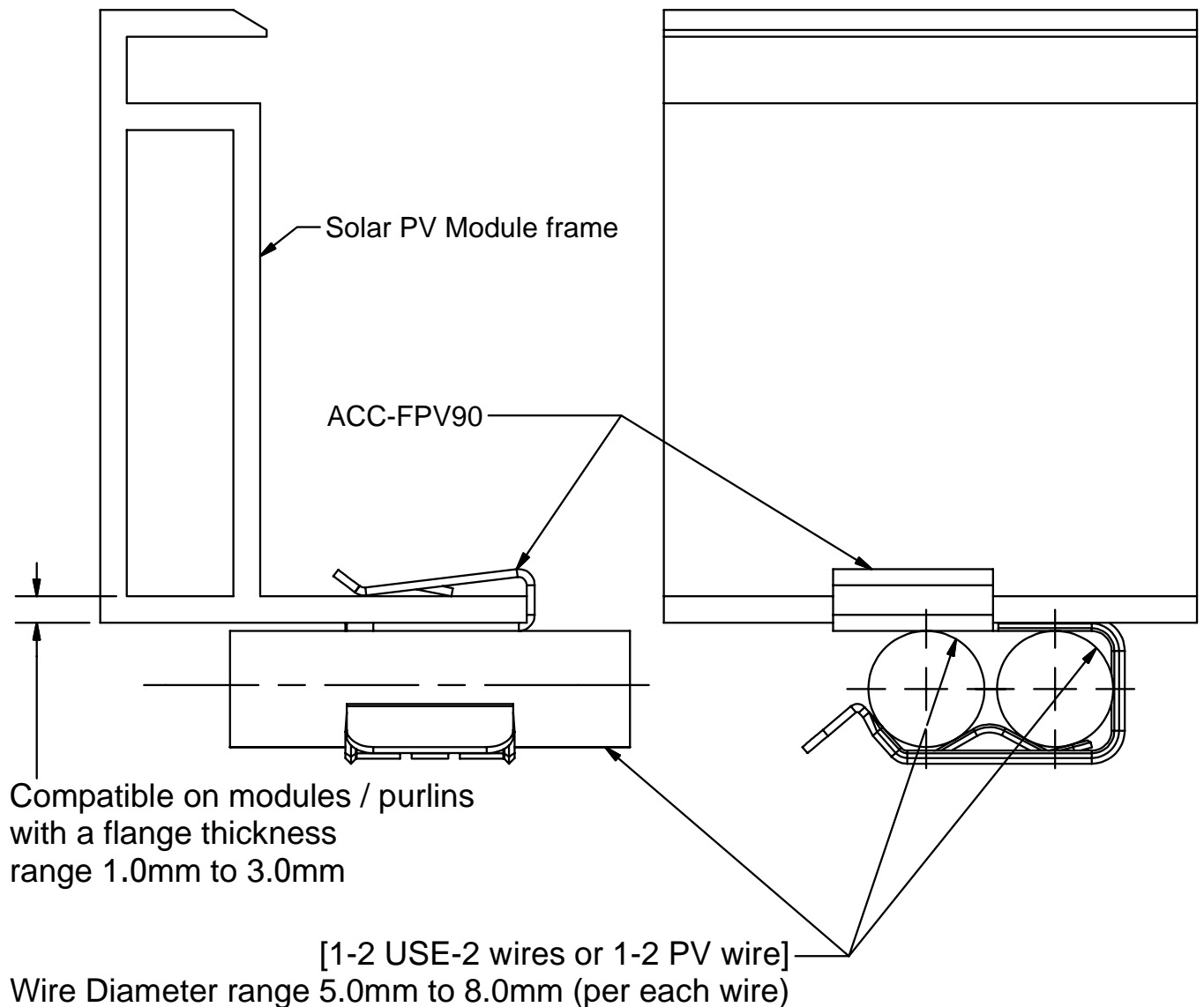

ACC-FPV90 SPECIAL FEATURES

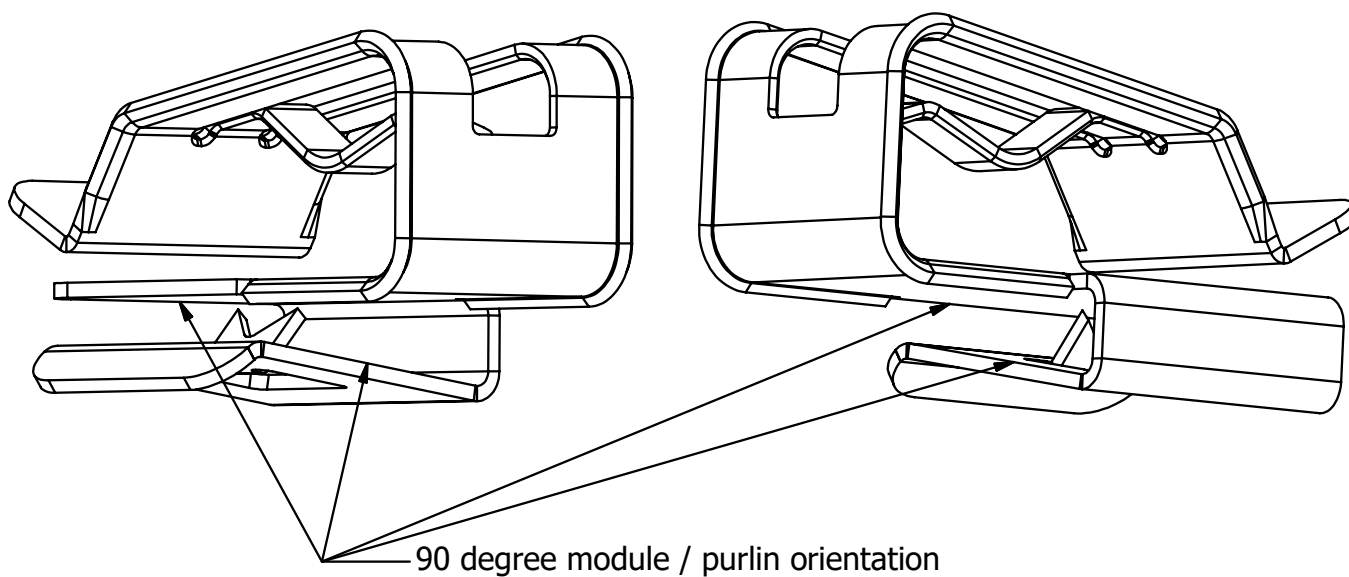
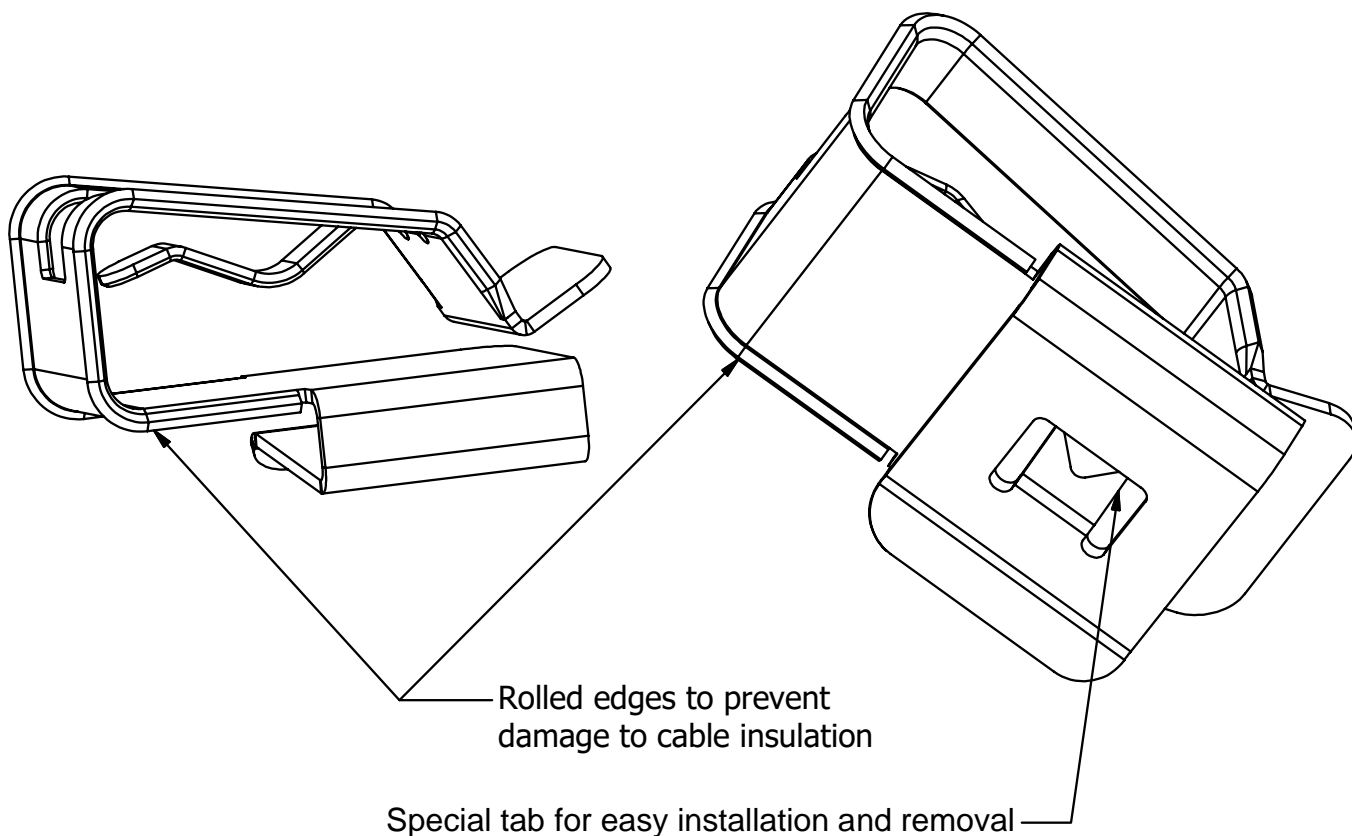

ACC-FPV90 OVERVIEW

Installs in a 90 degree orientation

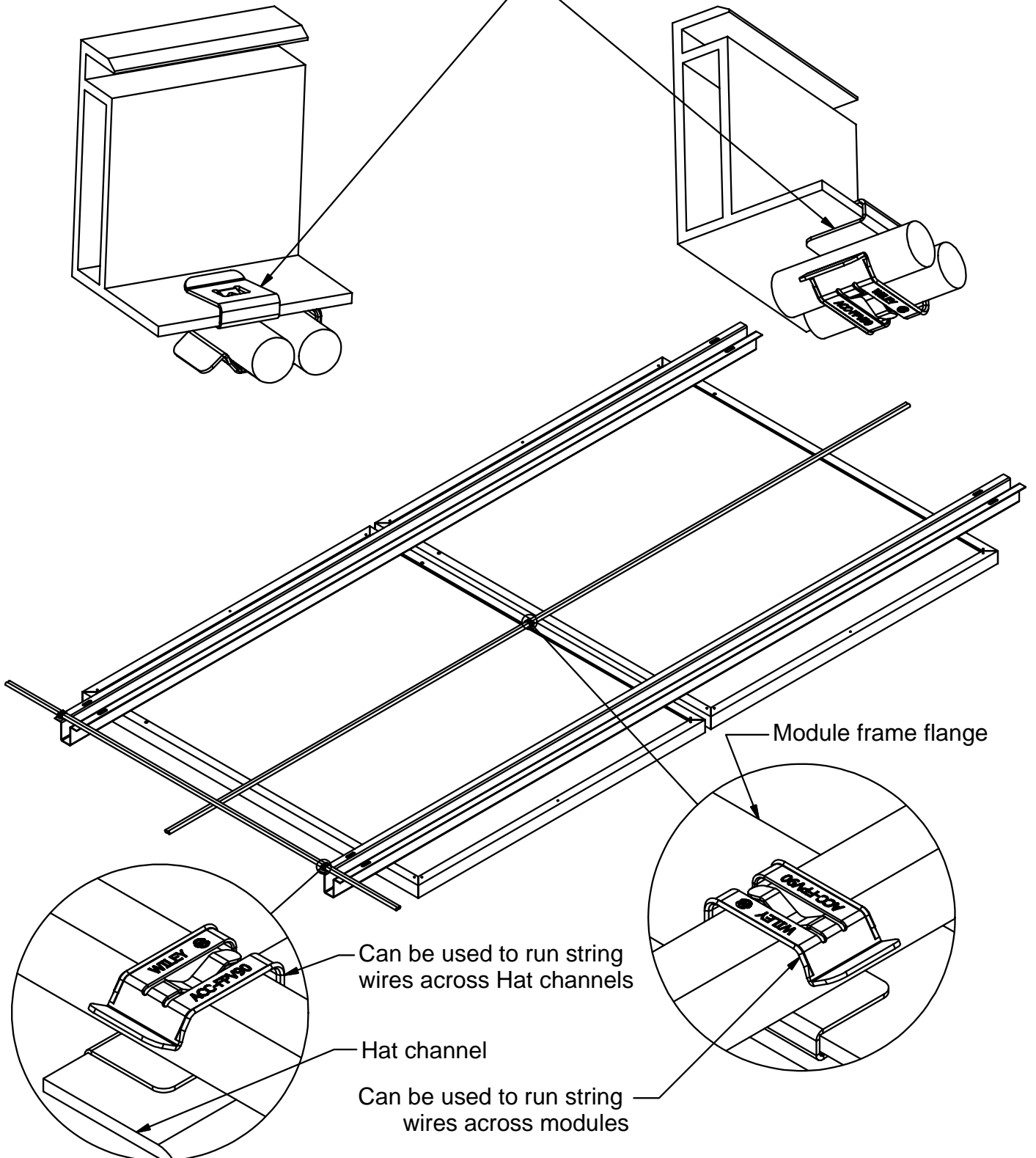

Customer Service Department
7 Aviation Park Drive
Londonderry, NH 03053
1-800-346-4175
1-603-647-5299 (International)

Note:

Application: Module frame flange / Purlin mounting.