

### 1500V BIG SERIES CONNECTORS FOR USE IN SOLAR PHOTOVOLTAIC SYSTEMS

用于最高1500V太阳能光伏系统的BIG系列连接器

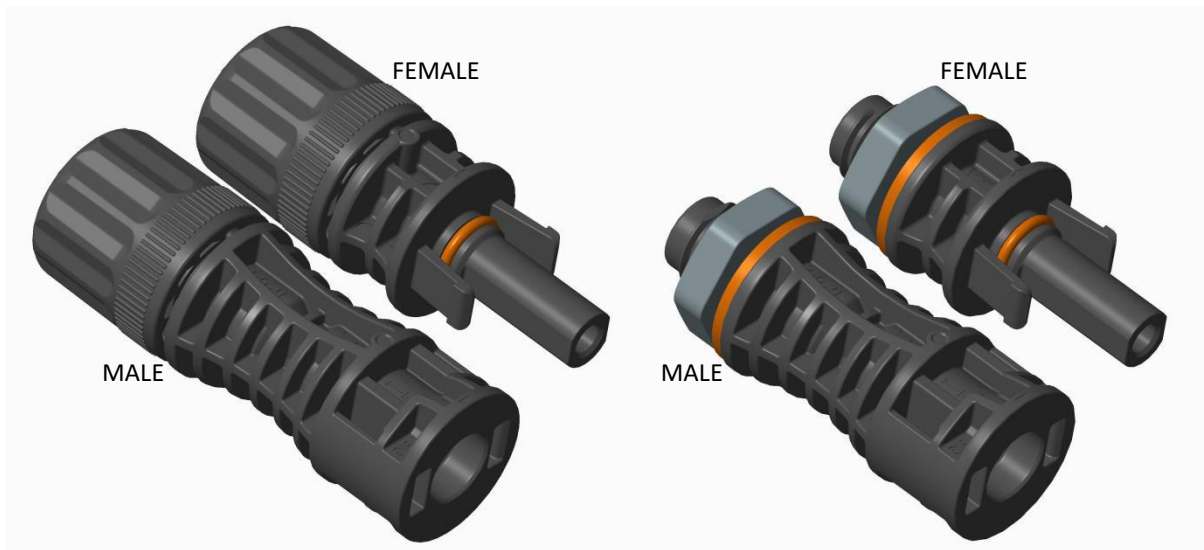

CABLE CONNECTOR 线端连接器

PANEL CONNECTOR 板端连接器

#### REVISION RECORD 修订纪要

REV 版次	DESCRIPTION 说明	DATE 日期
A	FIRST RELEASE 首次发行	22DEC2018



THE SPECIFICATIONS ARE SUBJECT TO CHANGE WITHOUT NOTICE! TONGLIN RESERVE ALL THE RIGHT OF FINAL INTERPRETATION!

规格如变更，不特别通知！本说明书最终解释权归通灵所有！

### 1 CAUTION安全说明

[1] PLEASE ISOLATE & DISCONNECT THE POWER SUPPLY BEFORE ASSEMBLING OR DISASSEMBLING. PLEASE DO NOT DISCONNECT UNDER LOAD. 请在连接器安装前及拆卸前必须断开电源。请不要在负载状态下断开连接。

[2] TO AVOID THE FAILURE (CRACK, BROKEN AND ETC), PLEASE DO NOT USE OR TOUCH THE SENSITIVE CHEMICALS ANYTIME. ALSO PLEASE CHECK AND FOLLOW THE INSTRUCTION OF TL-CABLE01/01S SERIES FOR THE CHEMICALS LIST. ALSO, PLEASE GET ASSEMBLY AND PRODUCTION UNDER 25°C ENVIRONMENT.

请参照江苏通灵电器股份有限公司在有关TL-CABLE01/01S系列说明书内的化学品清单指引 ([www.jstl.com.cn](http://www.jstl.com.cn)), 不要使用或接触敏感化学品, 避免连接器产生开裂及其他失效风险, 同时也推荐在室温25°C环境下安装生产。

### 2 TECHNICAL DESCRIPTION技术信息

#### [1] NOMENCLATURE FOR BIG CONNECTORS连接器系列命名规则BIG $abcde\ fgh$

BIG $bcde\ fgh$ 线端连接器、BIG $bcde\ fgh$  M12板端连接器、BIGQ $bcde\ fgh$  M14板端连接器

PRODUCT LINE	a-PRODUCT TYPE	b-INTERFACE	c-TERMINAL TYPE	d-CABLE/TERMINAL SIZE
BIG: BIG CONN	C: CABLE CONN M16	F: FEMALE	A: STAMPING FORMED	2: 2.5mm <sup>2</sup> /14AWG
	P: PANEL CONN M12	M: MALE	B: MACHINED	4: 4.0mm <sup>2</sup> /12AWG
	Q: PANEL CONN M14			6: 6.0mm <sup>2</sup> /10AWG
				8: 10.0mm <sup>2</sup> /8AWG

e-HOUSING MATL	f-CAP MATL	g-COLLET MATL	h-NUT MATL
E: EXL9034(f1)	X: A3XZG5(f1)	U: C3U(f1)	X: A3XZG5(f1)
V: PV40Z(f1)	T: A 21T4 V25(f1)	L: A 50X1(f1)	T: A 21T4 V25(f1)
Z: 644Z(f1)(c)	V: PV40Z(f1)	V: PV40Z(f1)	R: FR50(+)(f1)
	0: w/o CAP	0: w/o COLLET	0: w/o NUT

#### [2] RATED CURRENT AND SPECIFICATION额定电流及其他性能参数

FOR BIG CONN SERIES, THE RATING CURRENT IS JUST FOLLOWING THE ASSIGNED MAXIMUM AMPERE RATING OF CONDUCTOR SIZE AS PER UL486A/UL486B TABLE 7 & THE NEC TABLE 310.15(B)(2)(a) & 310.15(B)(17).

BIG连接器额定电流建议参照美国NEC电工法规表310.15(B)(2)(a) & 310.15(B)(17)及UL486A/UL486B表7的标准规定而应用。

RATED VOLTAGE	1500V
RATED CURRENT	40A MAX (14AWG/2.5mm <sup>2</sup> ) 45A MAX (12AWG/4.0mm <sup>2</sup> ) 55A MAX (10AWG/6.0mm <sup>2</sup> ) 80A MAX (8AWG/10.0mm <sup>2</sup> )
PROTECTION DEGREE	IP68 MATED & IP2X UNMATED
OPERATION TEMPERATURE	-40°C...+85°C
CONTACT RESISTANCE	0.25 mΩ TYP
FLAME CLASS	UL94 V-0
APPROVALS	UL6703/CSA-C22.2 No. 182.5, QI/Q2.QI/Q8.E342623 IEC62852/EN62852, R50424961

### [4] CABLE TYPE 线缆种类

UL4703.ZKLA PV WIRE & EN50618 H1Z2Z2-K PV CABLES

14AWG/2.5mm<sup>2</sup>

12AWG/4.0mm<sup>2</sup>

10AWG/6.0mm<sup>2</sup>

8AWG/10.0mm<sup>2</sup>

### [5] CONNECTOR TYPE 连接器线端和板端

#### CABLE CONNECTOR 线端连接器BIGC(\*)

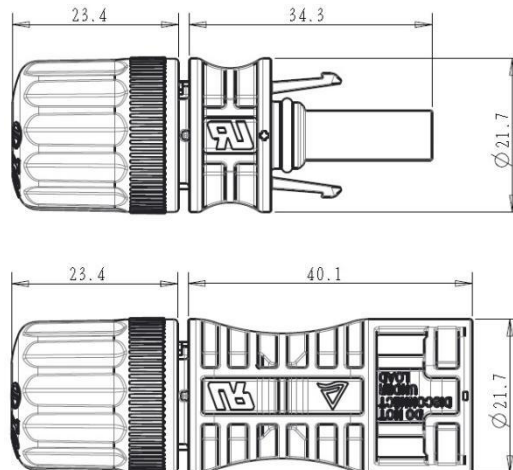

#### PANEL CONNECTOR 板端连接器BIGP/Q(\*)

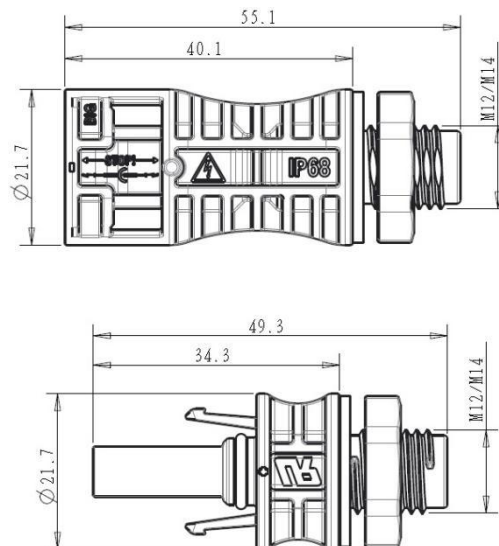

### [6] TOOLS REQUIRED 工具要求

STRIPPING PLIERS: TONGLIN/RENNSTEIG, BIGS1/S2. ([www.rennsteig.us](http://www.rennsteig.us))

CRIMPING PLIERS: TONGLIN/RENNSTEIG, BIGC1/C2. ([www.rennsteig.us](http://www.rennsteig.us))

WRENCH TOOL: TONGLIN, BIGT. ([www.jstl.com.cn](http://www.jstl.com.cn))

# INSTRUCTION MANUAL

## 使用说明书



### 3 ASSEMBLY INSTRUCTION 组装说明

#### [1] STRIP WIRE 剥线

REMOVE THE INSULATION OF THE CABLE OVER A LENGTH OF 6.5mm TO 7.5mm.

除掉一段长度为 6.5mm 至 7.5 mm 电缆的绝缘层，并留意在剥线时不要切断单股电线，保持切口平齐。

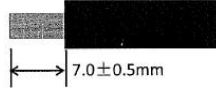

10AWG/6.0mm<sup>2</sup>  
12AWG/4.0mm<sup>2</sup>  
14AWG/2.5mm<sup>2</sup>



8AWG/10.0mm<sup>2</sup>  
10AWG/6.0mm<sup>2</sup>  
12AWG/4.0mm<sup>2</sup>



#### [2] CRIMPING 压线铆接

OPEN THE CLAMP AND HOLD, AND INSERT THE MALE OR FEMALE TERMINALS IN THE APPROPRIATE CROSSSECTION RANGE. THEN INSERT THE STRIPPED CABLE UNTIL THE STRANDS TOUCH THE CLAMPING BRACKET. COMPLETELY CLOSE THE CRIMPING PLIERS, AND MAKE A VISUAL CHECK OF THE CRIMP.

将压线钳的夹子打开并保持，并将公或母端子伸入合适的截面范围。然后插入剥线后的电缆直到电线接触紧固支架，并完全合上压接钳，完成铆压后进行外观检查及拉脱力抽查。



STAMPING & FORMED TERMINAL



MACHINED TERMINAL

# INSTRUCTION MANUAL

## 使用说明书



10AWG/6.0mm<sup>2</sup>  
12AWG/4.0mm<sup>2</sup>  
14AWG/2.5mm<sup>2</sup>



CRIMPING PLIERS FOR STAMPING & FORMED TERMINAL

8AWG/10.0mm<sup>2</sup>  
10AWG/6.0mm<sup>2</sup>  
12AWG/4.0mm<sup>2</sup>  
14AWG/2.5mm<sup>2</sup>



CRIMPING PLIERS FOR MACHINED TERMINAL

CABLE SIZE	PULL-OUT FORCE
14AWG/2.5mm <sup>2</sup>	223 N
12AWG/4mm <sup>2</sup>	312 N
10AWG/6mm <sup>2</sup>	356 N
8AWG/10mm <sup>2</sup>	401 N

### [3] ASSEMBLY PROCESS 组装及注意事项

INSERT THE CRIMPED TERMINAL INTO THE INSULATOR BODY FROM THE REAR UNTIL IT ENGAGES. PULL GENTLY ON THE LEAD TO CHECK THAT THE TERMINAL HAS ENGAGED CORRECTLY. TIGHTEN THE CABLE WITH THE TOOL BIGT AND A TORQUE WRENCH. 将压铆好的端子按极性从连接器后方插入并直到连接在一起。轻轻拉动电线，检查端子是否正确连接。利用工具 BIGT 和扭矩扳手将电缆扭紧，参考下表扭力值以及确保将螺帽拧至防松脱处并能扣住即可。考虑不同电线厂家的制作工艺及绝缘/护套材料软硬度，不可将螺帽强拧至本体底部(建议留 1.5mm 间隙)，避免损坏螺帽及防止变形。

CABLE SIZE	TIGHTENING TORQUE
14AWG/2.5mm <sup>2</sup>	4.5 N.m
12AWG/4mm <sup>2</sup>	4.5 N.m
10AWG/6mm <sup>2</sup>	4.5 N.m
8AWG/10mm <sup>2</sup>	4.5 N.m

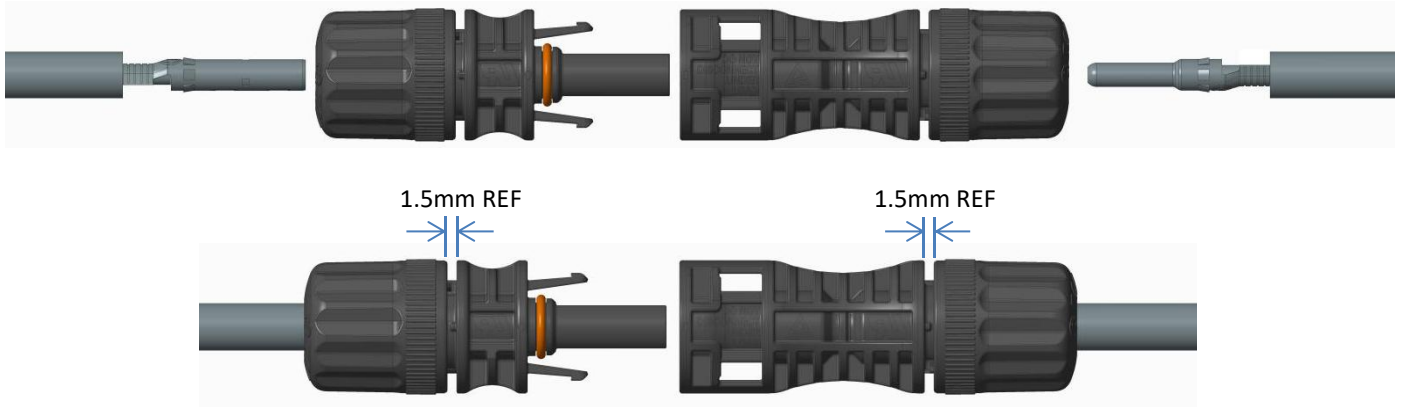

### [3.1] ASSEMBLY PROCESS FOR PANEL CONNECTOR 有关 BIGP/Q(\*)板端连接器安装注意事项

PLEASE DRILL ACCORDING TO THE FOLLOWING DIMENSIONS IN THE PANEL PLATE. FOR BOTH HORIZONTAL AND VERTICAL MOUNTING A SPACING OF AT LEAST 1" IS RECOMMENDED. BEFORE MOUNTING THE HOUSING THROUGH THE HOLE, THE GASKET MUST BE LOCATED ON THE HOUSING. AND, SCREW ON THE NUTS AND TIGHTEN THEM WITH THE TORQUE WRENCH(1.5 N.m). INSERT THE CRIMPED-ON CONTACTS INTO THE HOUSING FROM THE REAR SIDE UNTIL IT ENGAGES.

ALL POSITIONS MUST COMPLY WITH THE CREEPAGE DISTANCES UNDER UL6703 & IEC62852 CLAUSE 5.18.3.

先在面板上按图下尺寸钻孔(推荐 D 型孔), 并确保水平或垂直方向中心距间隔不小于 1 英寸。而且, 在安装前需将密封圈留在连接器本体上, 然后插入面板孔位, 并拧紧螺母(1.5 N.m)。最后将压铆好的端子按极性插入连接器本体。

安装板端连接器时须确保任意位置符合 UL6703 和 IEC62852 标准第 5.18.3 条款所描述的爬电距离要求。

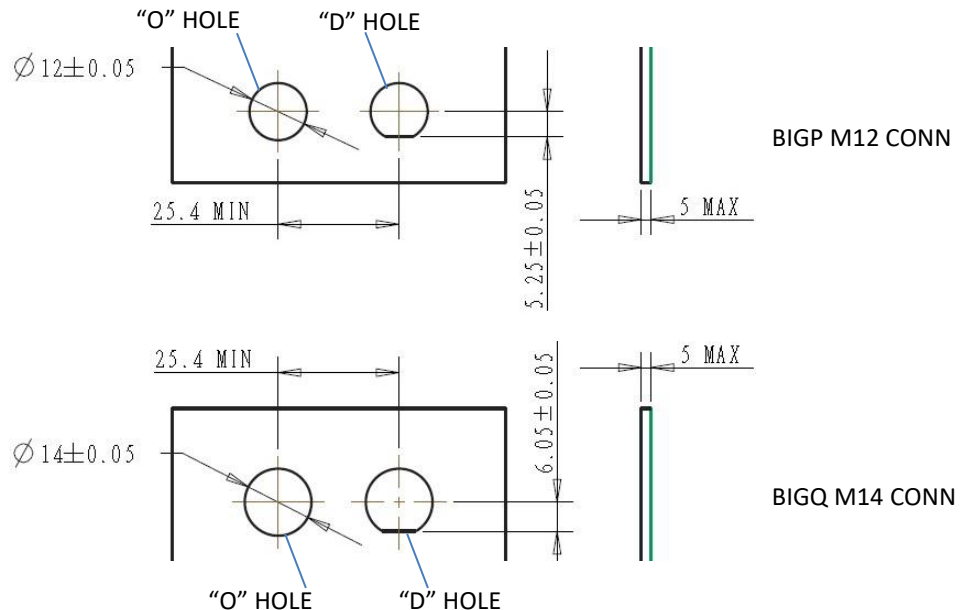



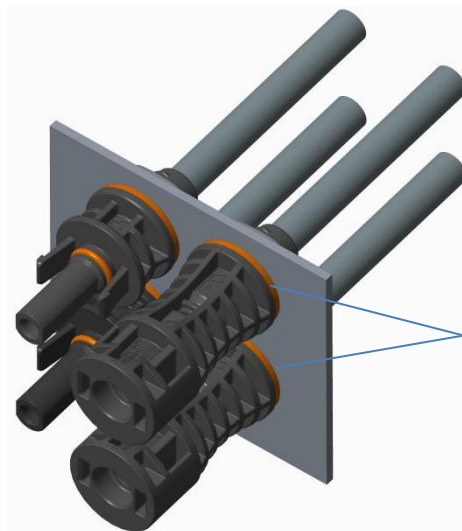
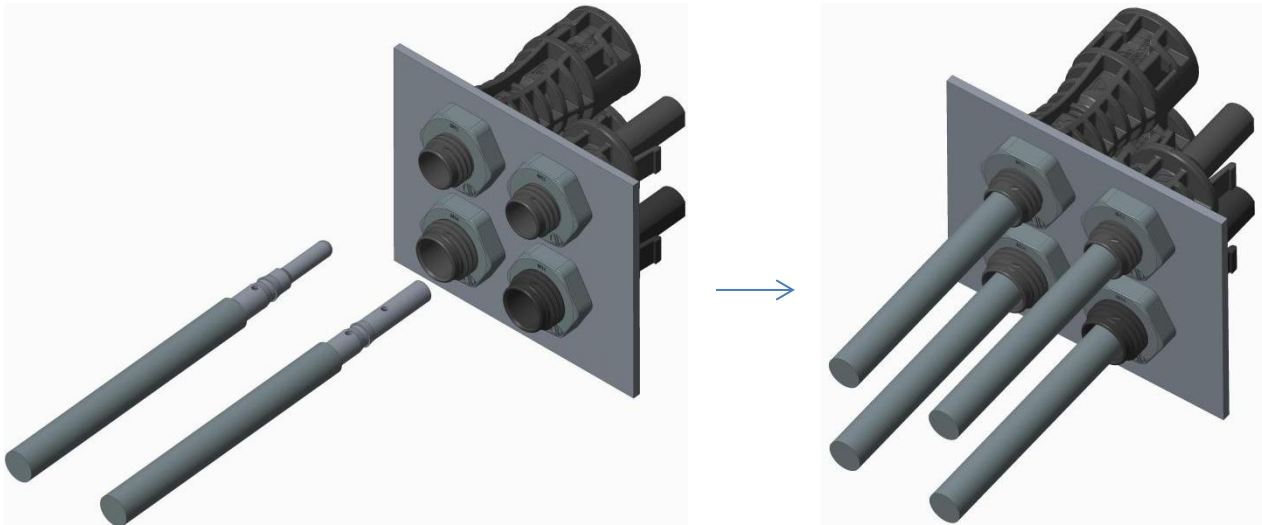

THE FLAT GASKET MUST LIE  
EVEN ON THE OUTER SIDE OF  
THE MOUNTING SURFACE  
确保密封圈安装在本体一侧  
(非螺母一侧)

#### [4] CONNECTING 耦合连接

PLUG THE MALE & FEMALE CONNECTORS TOGETHER UNTIL THEY CLICK INTO PLACE, AND CHECK THAT THEY ARE CORRECTLY ENGAGED BY PULLING ON THE CABLE COUPLING.

将公/母连接器插在一起并安装到位，通过拉动电线检查是否正确连接。



#### [5] DISCONNECTING 拆开

INSERT THE RELEASING PINS OF BIGT THROUGH THE OPENINGS PROVIDED IN THE MALE CONNECTOR ONTO THE LATCHES OF THE FEMALE CONNECTOR AND SEPARATE THE HALVES OF THE COUPLING.

将 BIGT 开锁工具的两脚插入连接器卡扣处的开口中，将耦合的连接器分开。



### [6] CABLE LAYOUT 连接器电线弯曲示意

FOLLOW THE CABLE MANUFACTURER WITH REGARD TO THE PERMITTED BENDING RADIUS, AND MAKE SURE THAT THE BENDING RADIUS OF THE CABLE IS AT LEAST 20mm.

参照并评估电线制造商的规格是否符合允许的弯曲半径，并确保距离电线的弯曲半径至少为 20mm。

